

# Owner's Manual & Safety Instructions

**Save This Manual** Keep this manual for the safety warnings and precautions, assembly, operating, inspection, maintenance and cleaning procedures.

## TOWABLE BACKHOE



**U-DIG 30-40 Series**

**Phone: (519) 949-2693**

### **WARNING!** **IMPORTANT INFORMATION**

The Hitch Coupler **MUST** be properly secured to the hitch ball of the towing vehicle. After assembly and attachment, pull up and down on the Hitch Coupler to make sure the hitch ball is fitting snugly in the Hitch Coupler. **There must be no play between the hitch ball and Hitch Coupler.** If there is play, tighten the Adjustment Nut until no play is present. If the Adjustment Nut is too tight, the Handle will not lock. **Carefully read and follow the complete instructions in this manual BEFORE setup or use.**

If the Coupler is not secured properly, the ball could come loose while the Trencher is in motion, possibly causing property damage, **SERIOUS PERSONAL INJURY, or DEATH.**

Serial No. \_\_\_\_\_

Order No. \_\_\_\_\_

While transporting make sure all pins are inserted Correctly .

# U-DIG INC



**⚠ DANGER**

Using an engine indoors  
**CAN KILL YOU IN MINUTES.**

Engine exhaust contains carbon monoxide.  
This is a poison you cannot see or smell.



**NEVER** use  
inside a home or  
garage, **EVEN IF**  
doors and  
windows are  
open.



**Only use OUTSIDE**  
and far away from  
windows, doors,  
and vents.





**⚠ WARNING**

Read this material before using this product.  
Failure to do so can result in serious injury.  
**SAVE THIS MANUAL.**



## Specifications



Displacement		6.5hp – 15hp
Engine Type		Horizontal Single Cylinder
Engine Family		Lifan
Cooling System		Forced air cooled
Fuel	Type	87+ octane unleaded gasoline
	Capacity	1.72 Gallon
Engine Oil	Type SAE	10W-30 above 32° F 5W-30 at 32° F or below
	Capacity	1 Quart
Run Time @ 50% Load with full tank		3 hours
Sound Level		106 dB
Bore x Stroke		80 mm x 60 mm
Compression Ratio		8.2:1
Rotation <small>viewed from PTO (power takeoff - the output shaft)</small>		Counterclockwise
Shaft	Shaft	1" x 3.48"
	Keyway	1/4"(6.3 mm)
	End Tapped	7/16 - 20
Spark Plug	Type	F6TC (Torch)
	Gap	0.7 - 0.8 mm
Valve Clearance	Intake	0.006" ± 0.0008"
	Exhaust	0.008" ± 0.0008"
Speed	Idle	1,740± 50 RPM
	Maximum	3,600 RPM
Battery Required		12V 18Ah
Hydraulic Oil		5 Gallons
Machine Hydraulic Oil		AW32
Maximum Digging Reach U-Dig30 - U-Dig40		7 - 10 Feet
Spool Valve U-Dig30 - U-Dig40		Rated 15
Pump		Rated 2.7-12 GPM
Boom Travel		140° Left/Right
Bucket Sizes		8"-12"-15"-24"
Hitch Ball size		2" Diameter

## WARNING SYMBOLS AND DEFINITIONS

	This is the safety alert symbol. It is used to alert you to potential personal injury hazards. Obey all safety messages that follow this symbol to avoid possible injury or death.
	Indicates a hazardous situation which, if not avoided, will result in death or serious injury.
	Indicates a hazardous situation which, if not avoided, could result in death or serious injury.
	Indicates a hazardous situation which, if not avoided, could result in minor or moderate injury.
	Addresses practices not related to personal injury.

### Symbol Definitions

Symbol	Property or Statement
<b>RPM</b>	Revolutions Per Minute
<b>HP</b>	Horsepower
	WARNING marking concerning Risk of Eye Injury. Wear ANSI-approved safety goggles with side shields.
	Read the manual before set-up and/or use.
	WARNING marking concerning Risk of Hearing Loss. Wear hearing protection.

Symbol	Property or Statement
	WARNING marking concerning Risk of Respiratory Injury. Operate engine OUTSIDE and far away from windows, doors, and vents.
	WARNING marking concerning Risk of Fire while handling fuel. Do not smoke while handling fuel.
	WARNING marking concerning Risk of Fire. Do not refuel while operating. Keep flammable objects away from engine.

## IMPORTANT SAFETY INSTRUCTIONS



**WARNING! Read all instructions.**

**Failure to follow all instructions listed below may result in fire, serious injury and/or DEATH.** The warnings and precautions discussed in this manual cannot cover all possible conditions and situations that may occur. It must be understood by the operator that common sense and caution are factors which cannot be built into this product, but must be supplied by the operator.

### SAVE THESE INSTRUCTIONS

### Set up Precautions

1. Gasoline fuel and fumes are flammable, and potentially explosive. Use proper fuel storage and handling procedures. Do not store fuel or other flammable materials nearby.
2. Have multiple ABC class fire extinguishers nearby.
3. This equipment has a spark arresting muffler included. A spark arresting muffler is required by law in California, on some US Forest Service land, and possibly in other areas or situations.
4. Set up and use only on a flat, level, well-ventilated surface.
5. Wear ANSI-approved safety goggles, heavy-duty work gloves, and dust mask/respirator during set up.
6. Use only lubricants and fuel recommended in the Specifications chart of this manual.

## Operating Precautions

1.



**CARBON MONOXIDE HAZARD Using an engine indoors CAN KILL YOU IN MINUTES.** Engine exhaust contains carbon monoxide. This is a poison you cannot see or smell.

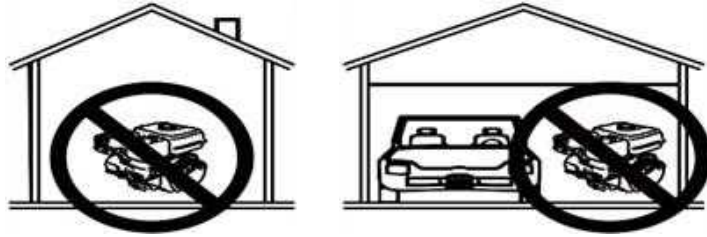

NEVER use inside a home or garage, EVEN IF doors and windows are open.

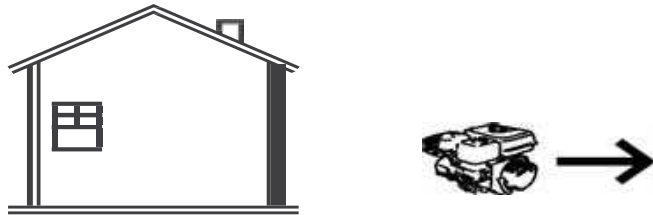

Only use OUTSIDE and far away from windows, doors, and vents.

2. Contact local utility companies before beginning any project. Buried utility lines may not be marked and, if struck, can cause **SERIOUS PERSONAL INJURY OR DEATH**.
3. Keep children away from the equipment, especially while it is operating.
4. Keep all spectators at least 20 feet from the equipment during operation.
5. Fire Hazard! Do not fill fuel tank while engine is running. Do not operate if gasoline has been spilled. Clean spilled gasoline before starting engine. Do not operate near pilot light or open flame.
6. Do not touch engine during use. Let engine cool down after use.
7. Never store fuel or other flammable materials near the engine.
8. Industrial applications must follow OSHA requirements.
9. Do not leave the equipment unattended when it is running. Turn off the equipment (and remove safety keys, if available) before leaving the work area.
10. The equipment can produce high noise levels. Prolonged exposure to noise levels above 85 dBA is hazardous to hearing. Wear ear protection when operating the equipment or when working nearby while it is operating.
11. Wear ANSI-approved safety goggles and hearing protection during use.
12. Do not operate in explosive atmospheres, such as in the presence of flammable liquids, gases, or dust. Gasoline-powered engines may ignite the dust or fumes.
13. People with pacemakers should consult their physician(s) before use. Electromagnetic fields in close proximity to a heart pacemaker could cause pacemaker interference or pacemaker failure. Caution is necessary when near the engine's magneto or recoil starter.
14. Use only accessories that are recommended by U-Dig for your model. Accessories that may be suitable for one piece of equipment may become hazardous when used on another piece of equipment.
15. Stay alert, watch what you are doing and use common sense when operating this piece of equipment. Do not use while tired or under the influence of drugs, alcohol or medication.
16. Do not overreach. Keep proper footing and balance at all times. This enables better control of the equipment in unexpected situations.
17. Use this equipment with both hands only. Using equipment with only one hand can easily result in loss of control.
18. Dress properly. Do not wear loose clothing or jewelry. Keep hair, clothing and gloves away from moving parts. Loose clothes, jewelry or long hair can be caught in moving parts.
19. Parts, especially exhaust system components, get very hot during use. Stay clear of hot parts.
20. Do not cover the engine or equipment during operation.
21. Keep the equipment, engine, and surrounding area clean at all times.
22. Use the equipment, accessories, etc., in accordance with these instructions and in the manner intended for the particular type of equipment, taking into account the working conditions and the work to be performed. Use of the equipment for operations different from those intended could result in a hazardous situation.
23. Do not operate the equipment with known leaks in the engine's fuel system.
24. **WARNING:** Some dust created by power sanding, sawing, grinding, drilling, and other construction activities, contains chemicals known to the State of California to cause cancer and birth defects or other reproductive harm. Some examples of these chemicals are:
  - Lead from lead-based paints
  - Crystalline silica from bricks and cement or other masonry products
  - Arsenic and chromium from chemically treated lumberYour risk from these exposures varies, depending on how often you do this type of work. To reduce your exposure to these chemicals: work in a well ventilated area, and work with approved safety equipment, such as those dust masks that are specially designed to filter out microscopic particles.

## Operating Precautions (cont.)

---

25. Do not smoke, or allow sparks, flames, or other sources of ignition around the equipment, especially when refuelling.
26. **WARNING:** This product contains or, when used, produces a chemical known to the State of California to cause cancer and birth defects or other reproductive harm.
27. **WARNING:** This product contains di (2-ethylhexyl) phthalate (DEHP), a chemical known to the State of California to cause cancer and birth defects or other reproductive harm.
28. Never place your hands or body near a hydraulic fluid leak. High-pressure fluid can be forced under the skin resulting in serious injury.
29. When spills of fuel or oil occur, they must be cleaned up immediately. Dispose of fluids and cleaning materials as per any local, state, or federal codes and regulations. Store oil rags in a bottom-ventilated, covered, metal container.
30. Keep hands and feet away from moving parts. Do not reach over or across equipment while operating.
31. Before use, check for misalignment or binding of moving parts, breakage of parts, and any other condition that may affect the equipment's operation. **If damaged, have the equipment serviced before using.** Many accidents are caused by poorly maintained equipment.
32. Use the correct equipment for the application. Do not modify the equipment and do not use the equipment for a purpose for which it is not intended.

## Transport Precautions

---

1. Only use a suitable means of transport and lifting devices with sufficient weight bearing capacity when transporting the equipment.
2. Properly secure the equipment to transport vehicle to prevent it from rolling, slipping, and tilting.
3. Always make sure the hitch coupler is securely fixed to the vehicle before moving it. If the Coupler is not secured properly, the link could come loose while the trailer is in motion, possibly causing property damage, **SERIOUS PERSONAL INJURY**, or **DEATH**.
4. Do not exceed 55 MPH when towing the Trencher.
5. Do not tow the Trencher on roads or highways until you check with your local transportation office about your local transportation regulations.

## Service Precautions

---

1. **Before service, maintenance, or cleaning:**
    - a. **Turn the engine switch to its "OFF" position.**
    - b. **Allow the engine to completely cool.**
    - c. **Then, remove the spark plug wire from the spark plug.**
  2. Keep all safety guards in place and in proper working order. Safety guards include muffler, air cleaner, mechanical guards, and heat shields, among other guards.
  3. **Do not alter or adjust any part of the equipment or its engine that is sealed by the manufacturer or distributor. Only a qualified service technician may adjust parts that may increase or decrease governed engine speed.**
  4. Wear ANSI-approved safety goggles, heavy-duty work gloves, and dust mask/respirator during service.
  5. Do not allow the hydraulic hose to come in contact with any hot part of the unit. The hose might be damaged, possibly causing it to burst or leak under high pressure.
  6. Maintain labels and nameplates on the equipment. These carry important information.
  7. Have the equipment serviced by a qualified repair person using only identical replacement parts. This will ensure that the safety of the equipment is maintained. Do not attempt any service or maintenance procedures not explained in this manual or any procedures that you are uncertain about your ability to perform safely or correctly.  
Store equipment out of the reach of children.
  8. Follow scheduled engine and
  9. equipment maintenance.
- Refueling:**
1. Do not refill the fuel tank while the engine is running or hot.
  2. Do not smoke, or allow sparks, flames, or other sources of ignition around the equipment, especially when refuelling.
  3. Refuel in a well-ventilated area only.
  4. Wipe up any spilled fuel and allow excess to evaporate before starting engine.  
**To prevent FIRE, do not start the engine while the smell of fuel hangs in the air.**



**SAVE THESE INSTRUCTIONS.**

## Attaching the Leg Assembly

---

1. To use the Trencher, the Leg Assemblies must be installed next to the Boom and the Wheels and Axles moved to the rear.
  2. Move the Trencher to the work area
  3. Start the engine and use the Boom Controls to curl the Bucket toward the Boom without touching the ground. Moving the Bucket Assembly down to the ground will raise the Frame Assembly. Lift the Tires
  4. Ensure the controls will not be touched or bumped, and that the Trencher will remain motionless. Never place any part of your body under the Trencher.
  5. With the Tires off the ground, remove the Wheel and Axle to the operator's left and replace with the left side Extension Leg and Leg Assembly. Direct the Extension Leg so it turns toward the Bucket end of the Trencher. Secure with Lock Pin. Repeat procedure for the right side. Raise Bucket Assembly again to lower onto Leg Assembly, and turn Engine off.
  6. Using the jack stand to raise up the engine end of the trencher and disconnect from the Towing Hitch. Slide the Wheels and Axles into the engine end of the Frame. Secure each Axle with Lock Pin
- 

## Purging the Cylinder

1. Remove all Safety Locking Pins and disengage the Safety Latch and loosen Hydraulic Tank Fill Plug
2. Press forward on the Boom Swing Lever (located on Control Panel) until the Boom stops moving, then pull back on it until it moves in the other direction. Center the Boom.
3. Press forward on the Main Boom Lever until the Main Boom is fully raised. Then, press Forward on the Boom Extension Lever until the Boom is fully extended.
4. Press forward on the Bucket Lever until the Bucket is fully extended. Pull back on the Lever to retract it fully.
5. Pull back on the Boom Extension Lever until the Boom is pulled back all the way. Pull back on the Main Boom Lever until the Main Boom is lowered completely.
6. Adjust the Boom back to its rest position and replace all locking devices.
7. Shut off the Engine, check the Hydraulic Fluid level and refill as necessary.

**Note:** The Fill Plug is vented. When tightening the Fill Plug, tighten it securely then back it off slightly.

# Components and Controls

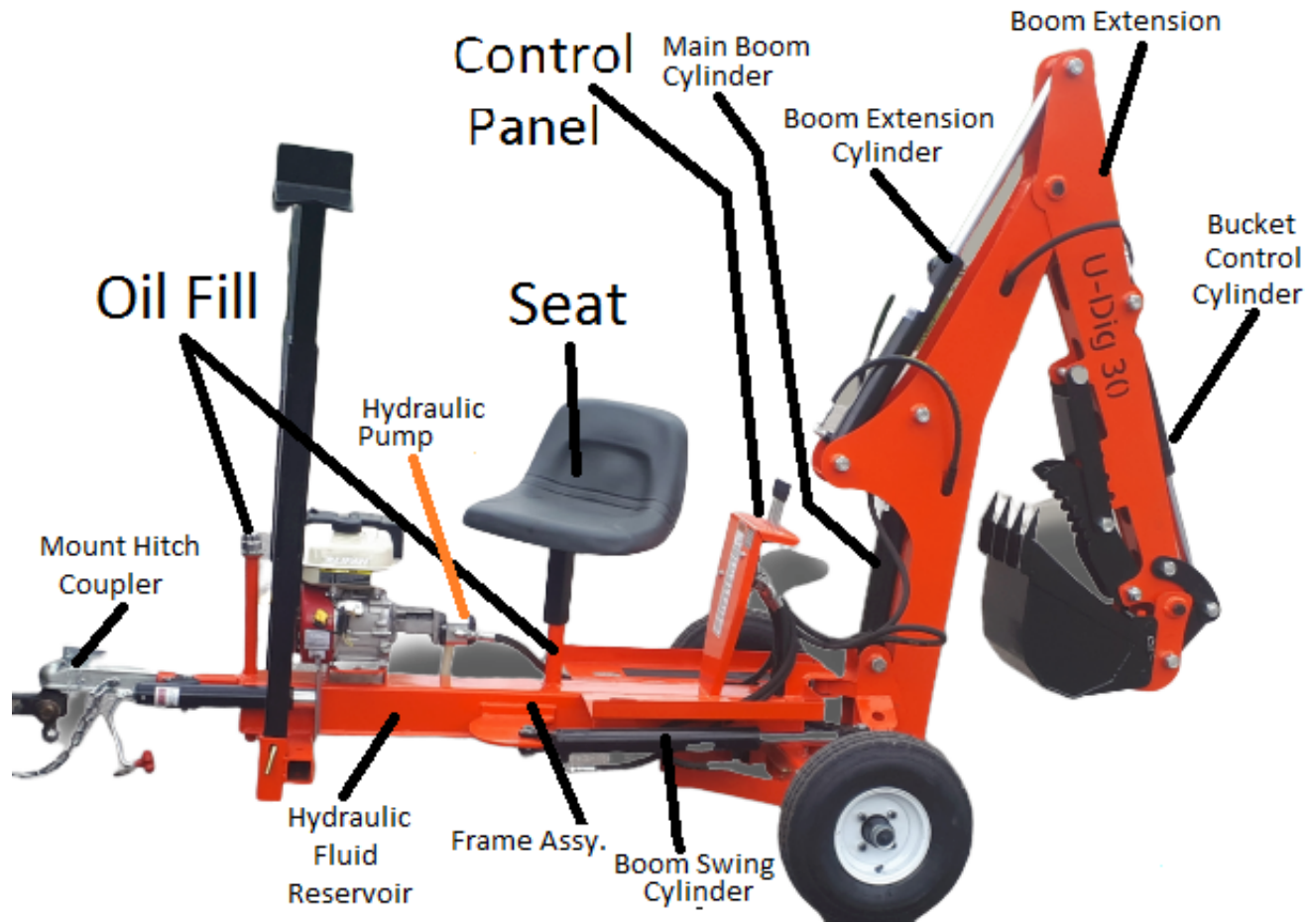
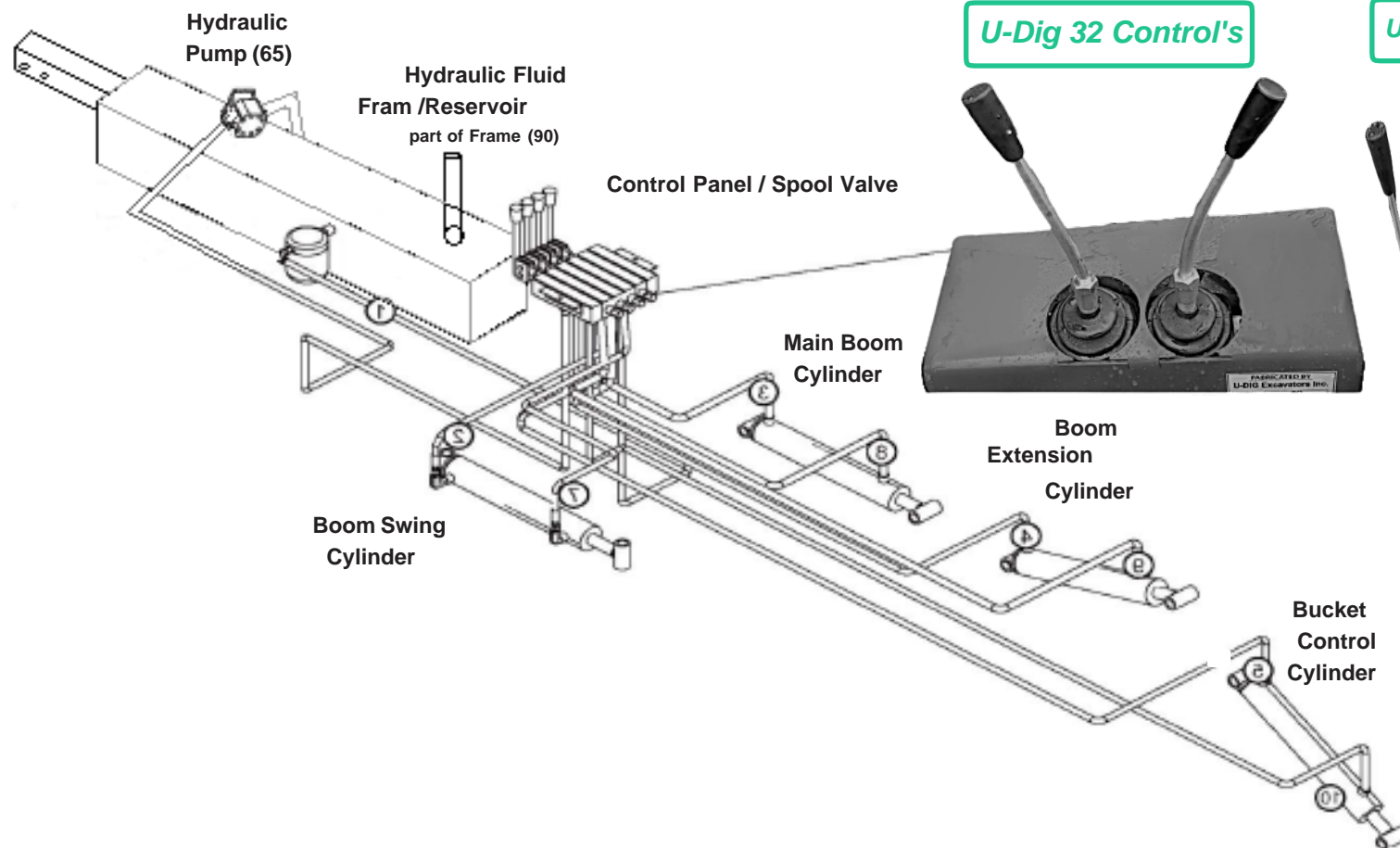
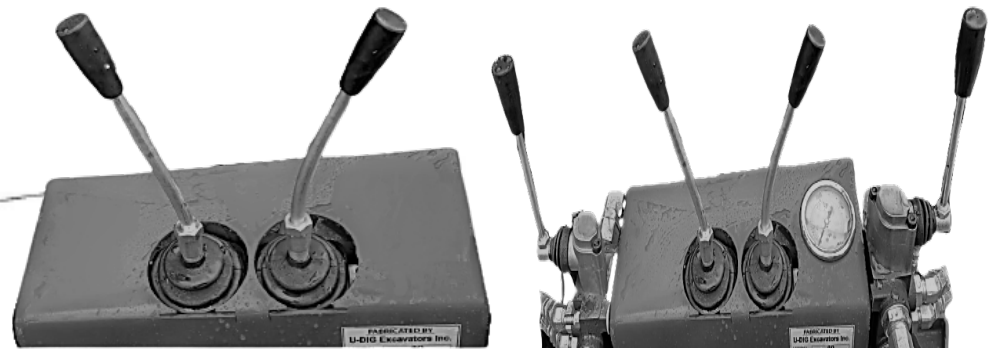

Figure B: Tow Configuration



**U-Dig 32 Control's**

**U-Dig 40 (With HY S) Control's**



## Components and Controls (cont'd)

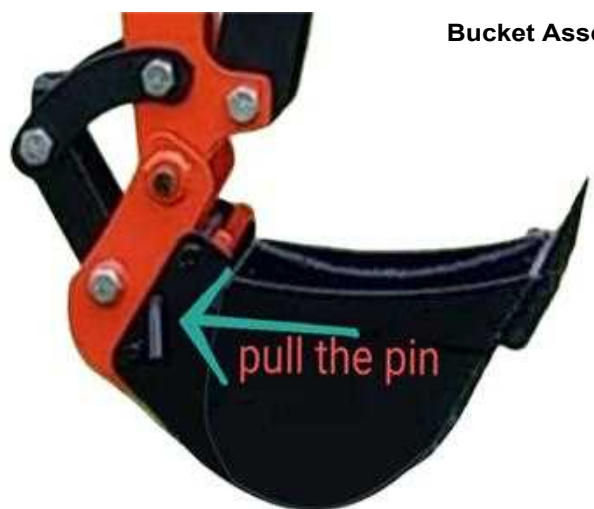

Bucket Assembly

Main Boom



Frame  
Assembly/  
Engine/Pump

2 Tires



Tractor Seat



Axle & Hub



Leg Assembly



Control Panel



## Operation



Read the **ENTIRE IMPORTANT SAFETY INFORMATION** section at the beginning of this manual including all text under subheadings therein before set up or use of this product.

## Pre-Start Checks

Inspect engine and equipment looking for damaged, loose, and missing parts before set up and starting. If any problems are found, do not use equipment until fixed properly.

### Checking and Filling Engine Oil

**NOTICE:** Your Warranty is VOID if the engine's crankcase is not properly filled with oil before each use. Before each use, check the oil level. Engine will not start with low or no engine oil.

1. Make sure the engine is stopped and is level.
2. Close the Fuel Valve.
3. Clean the top of the Dipstick and the area around it. Remove the Dipstick by turning it counterclockwise, and wipe it off with a clean, lint free rag.

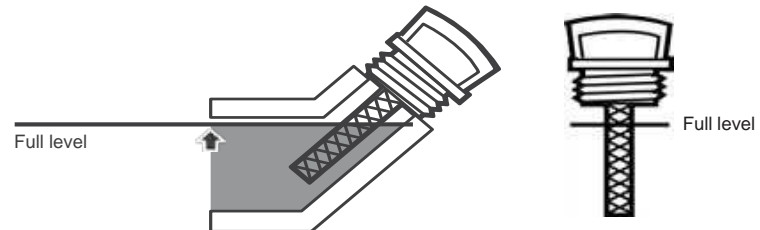

4. Reinsert the Dipstick without threading it in and remove it to check the oil level. The oil level should be up to the full level as shown above.
5. If the oil level is at or below the low mark add the appropriate type of oil until the oil level is at the proper level. SAE 10W-30 oil is recommended for general use. (The SAE Viscosity Grade chart on page 19 in the Maintenance section shows other viscosities to use in different average temperatures.)
6. Thread the dipstick back in clockwise.

**NOTICE:** Do not run the engine with too little oil. Engine will shut off if engine oil level is too low.

### Checking and Filling Fuel



**WARNING!** TO PREVENT SERIOUS INJURY FROM FIRE:

Fill the fuel tank in a well-ventilated area away from ignition sources. If the engine is hot from use, shut the engine off and

wait for it to cool before adding fuel. Do not smoke.

1. Clean the Fuel Cap and the area around it. Unscrew and remove the Fuel Cap.
2. Remove the Strainer and remove any dirt and debris. Then replace the Strainer.

**Note:** Do not use gasoline containing more than 10% ethanol (E10). Do not use E85 ethanol. Add fuel stabilizer to the gasoline or the Warranty is VOID.

**Note:** Do not use gasoline that has been stored in a metal fuel container or a dirty fuel container. It can cause particles to enter the carburetor, affecting engine performance and/or causing damage.

4. If needed, fill the Fuel Tank to about 1 inch under the fill neck of the Fuel Tank with 87 octane or higher unleaded gasoline that has been treated with a fuel stabilizer additive. Follow fuel stabilizer manufacturer's recommendations for use
5. Then replace the Fuel Cap. Wipe up any spilled fuel and allow excess to evaporate before starting engine. To prevent FIRE, do not start the engine while the smell of fuel hangs in the air.

## Starting the Engine

### Before Starting the Engine



Before starting the engine:

- a. Follow the Set Up Instructions to prepare the equipment.
- b. Inspect the equipment and engine.
- c. Fill the engine with the proper amount and type of both stabilizer-treated unleaded gasoline and oil.

d. Read the Equipment Operation section that follows.

## Engine Diagrams

---

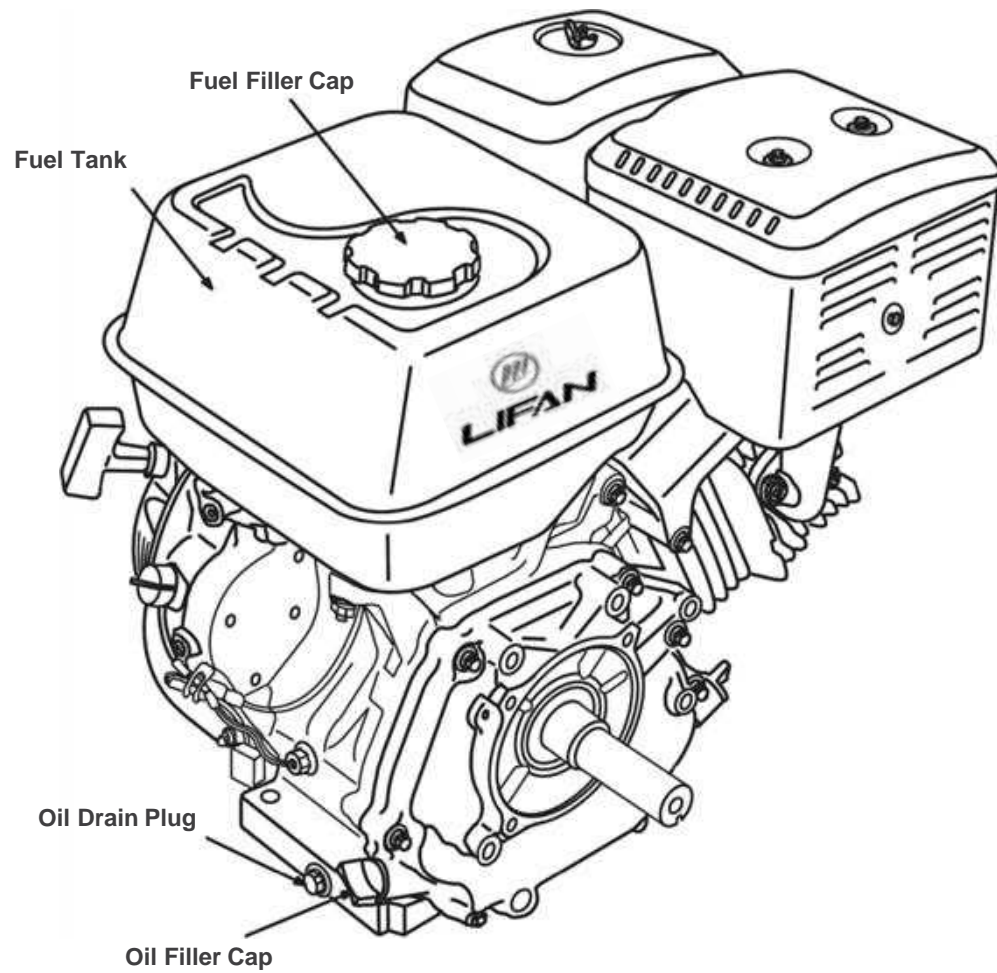
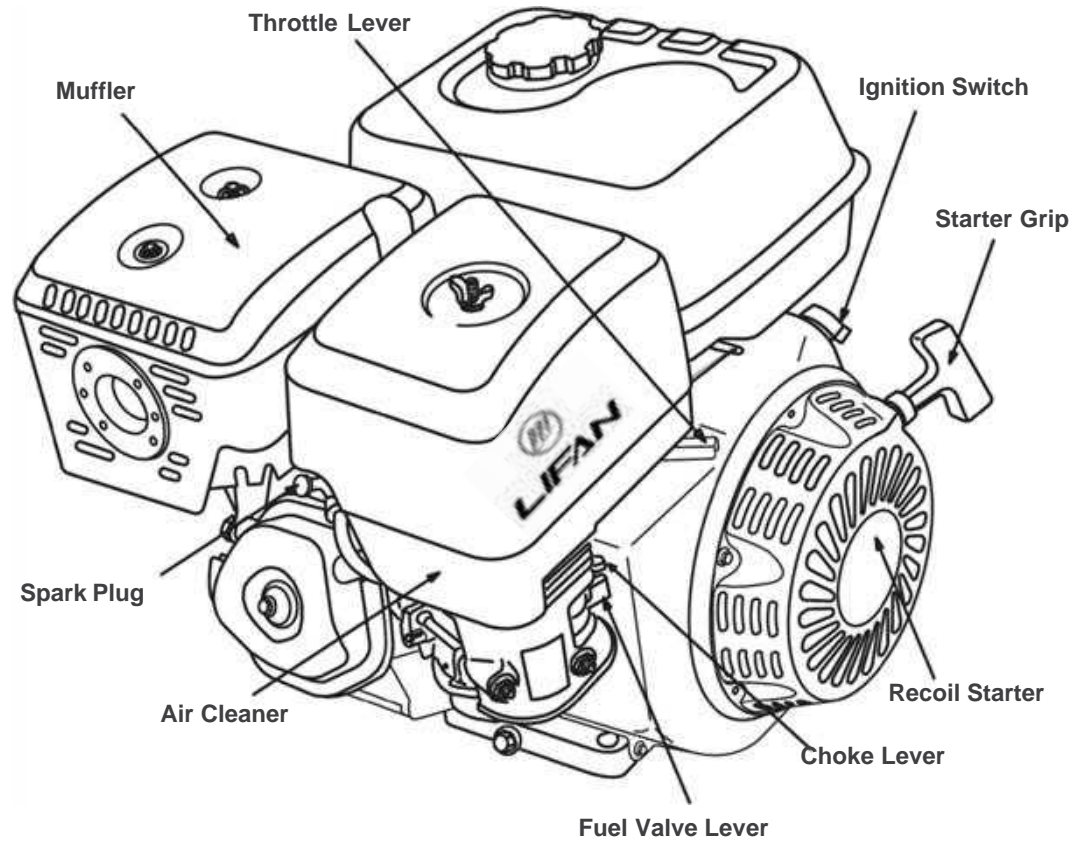

## Manual Start

1. Turn the Fuel Valve Lever to its "OPEN" position.

1

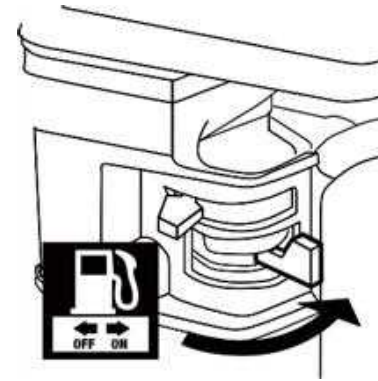

2. Turn the Ignition Switch to its ON or RUN position.

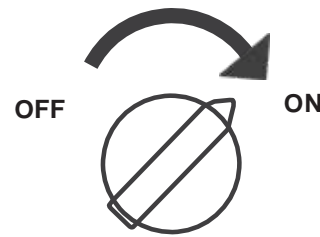

2

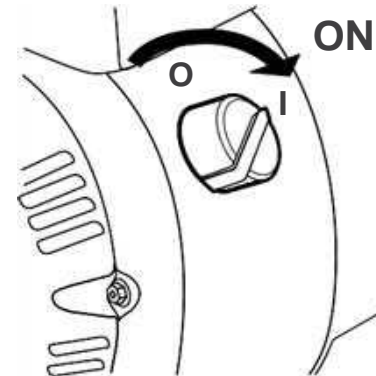

**Note:** If engine does not start, check engine oil level. Engine will not start with low or no engine oil.

3. Then, turn the engine Choke Lever to its "START" position.

Set the Choke Lever in the "RUN" position when starting a warm engine.

3

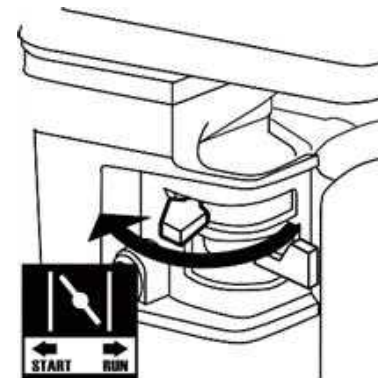

4. Grip the Starter Handle of the Engine loosely and pull it

slowly several times to allow the gasoline to flow into the Engine's carburetor. Then pull the Starter Handle gently until resistance is felt. Allow Cable to retract fully and then pull it quickly. Repeat until the engine starts.

4

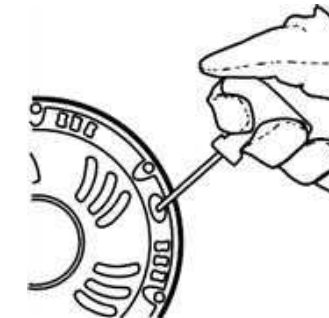

**Note:** Do not let the Starter Handle snap back against the engine. Hold it as it recoils so it doesn't hit the engine.

5. Allow the Engine to run for several seconds. Then, if

the Choke Lever is in the START position, move the Choke Lever very slowly to its RUN position.

5

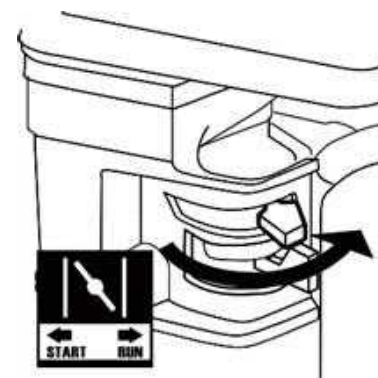

**Note:** Moving the Choke Lever too fast could stall the engine.

6. Slide the Throttle or Speed Control Lever to 1/3 away from the SLOW position (the "turtle"). Adjust as needed.

**Note:** Some tools have a Speed Control Lever located elsewhere on the tool which functions the same as the Throttle. Use the Speed Control Lever in place of the Throttle when the tool is so equipped.

6



**IMPORTANT:** Allow the engine to run at no load for five minutes after each start-up so that the engine can stabilize.

#### Break-in Period:

- a. Breaking-in the engine will help to ensure proper equipment and engine operation.
- b. The operational break-in period will last about 3 hours of use. During this period:
  - Do not apply a heavy load to the equipment.
  - Do not operate the engine at its maximum speed.
- c. The maintenance break-in period will last about 20 hours of use.
  - Change the engine oil after this period.

Under normal operating conditions subsequent maintenance follows the schedule explained in the MAINTENANCE section.

## Stopping the Engine

---

1. To stop the engine in an emergency, turn the Engine Switch off.
2. Under normal conditions, use the following procedure:
  - a. Turn the Engine Switch off.
  - b. Close the Fuel Valve.

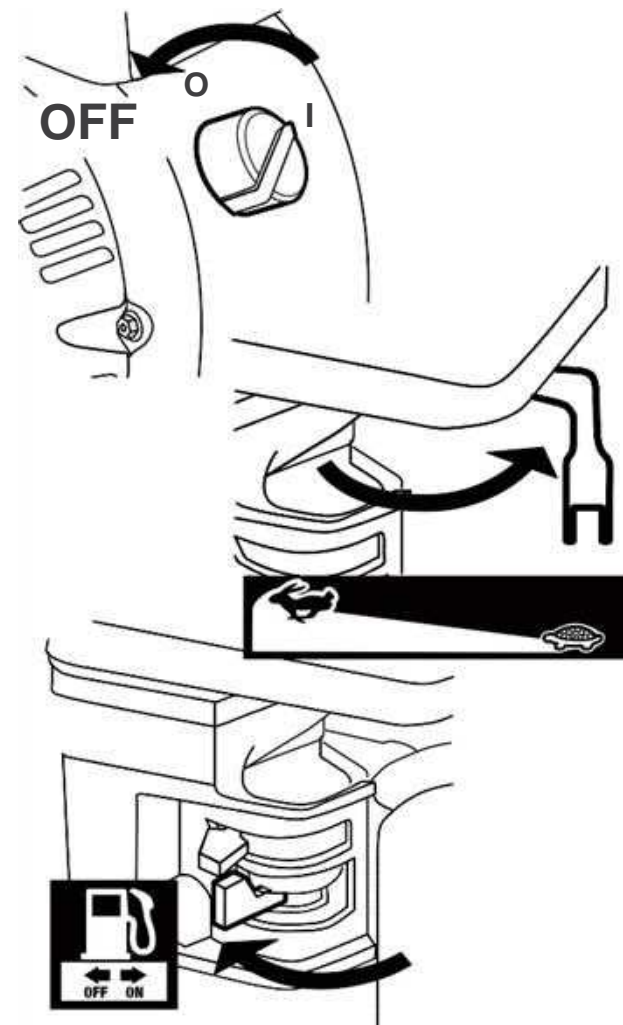

## General Operating Instructions

1. With the Engine running, sit in the Operator Seat and pull the Boom Lever control backward to raise the Main Boom. See Figure G.
2. Pull back on the Boom Extension Handle Control to raise the Boom Extension.
3. Push forward on the Bucket Handle Control to open the Bucket Assembly.
4. Push forward on the Boom Handle to lower the Boom until the Bucket reaches the ground.
5. Pull back on the Bucket Lever control until the Bucket scoops up the dirt.
6. Pull back on both the Boom and Boom Extension Control Levers to raise the load.
7. Press in, or push out, the Boom Swing Control Levers to move the Bucket left or right.

**Note:** The Boom's travel is 70 degrees left and 70 degrees right.

8. Press in on the Bucket control handle to dump the load.

### Moving the Trencher

1. One method for moving the Trencher around the work area is by using the Boom to push the Trencher across the ground.



**WARNING!** This technique can be difficult to control and should only be attempted by an experienced operator. The stability of the Trencher is dependent on the stability of the ground; if you choose to move the Trencher in this way, do so at your own risk. Do not use the Trencher near ditches or drop-offs.

2. Swing the Bucket inward so that the front of the Bucket, not the scoop, is facing downward. Press the Bucket down onto a solid piece of ground and press down hard enough to raise the front legs off the ground.
3. Carefully operate the controls to move the Boom and slowly roll yourself in the desired direction. Be certain that the Tires and the new resting places for the Legs all remain on solid, stable ground.
4. After you have repositioned the Trencher, raise the Boom to lower the Outriggers back onto the ground. The procedure can be repeated to move farther.

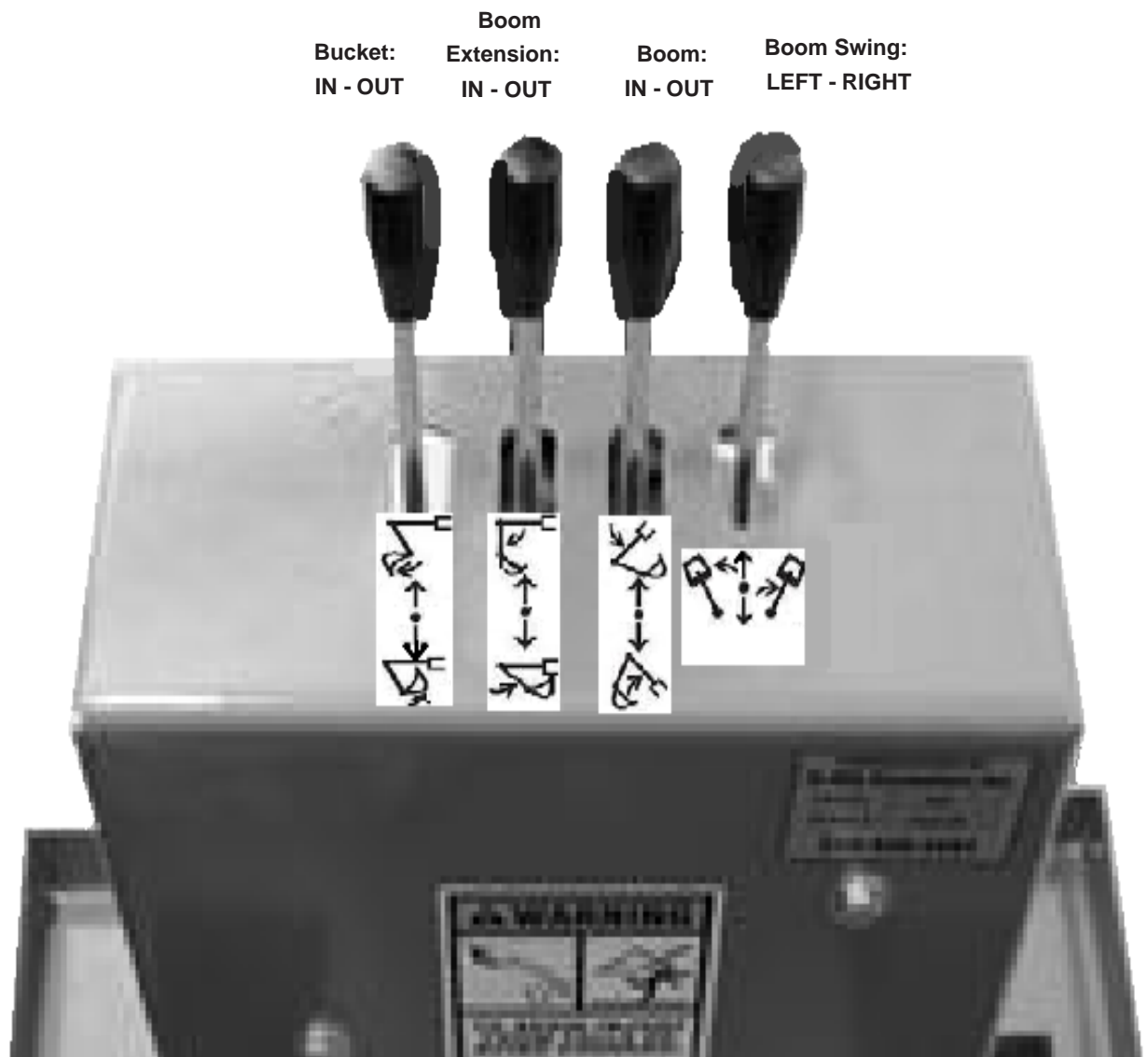

**Figure G: Operate controls by pushing in or pulling out.**

## WARNING

### TO PREVENT SERIOUS INJURY FROM ACCIDENTAL STARTING:

Turn the Power Switch of the equipment to its "OFF" position, wait for the engine to cool, and disconnect the spark plug cap before performing any inspection, maintenance, or cleaning procedures.

### TO PREVENT SERIOUS INJURY FROM EQUIPMENT FAILURE:

Do not use damaged equipment. If abnormal noise, vibration, or excess smoking occurs, have the problem corrected before further use.

Follow all service instructions in this manual. The engine may fail critically if not serviced properly.



Many maintenance procedures, including any not detailed in this manual, will need to be performed by a qualified technician for safety. If you have any doubts about your ability to safely service the equipment or engine, have a qualified technician service the equipment instead.

## Cleaning, Maintenance, and Lubrication Schedule

**Note:** This maintenance schedule is intended solely as a general guide. If performance decreases or if equipment operates unusually, check systems immediately. The maintenance needs of each piece of equipment will differ depending on factors such as duty cycle, temperature, air quality, fuel quality, and other factors.

**Note:** The following procedures are in addition to the regular checks and maintenance explained as part of the regular operation of the engine and equipment.

Procedure	Before Each Use	After 20 Operation Hour Break-in Period	Monthly or every 25 hr. of use	Every 3 mo. or 50 hr. of use	Every 6 mo. or 100 hr. of use	Yearly or every 300 hr. of use	Periodically
	✓	✓	✓	✓	✓	✓	✓
	✓	✓	✓	✓	✓	✓	✓
Brush off outside of engine	✓			✓	✓	✓	✓
Check engine oil level	✓				✓	✓	✓
Check air cleaner		✓	✓	✓	✓	✓	✓
Check deposit cup			✓	✓	✓	✓	✓
Change engine oil			✓	✓	✓	✓	✓
Clean/replace air filter			✓*	✓*	✓*	✓*	✓*
Check and clean spark plug				✓	✓	✓	✓
change filters					✓	✓	✓
Replace fuel Filter							
Replace spark plug						✓	✓
1. Clean fuel tank, strainer and carburetor 2. Clean carbon build-up from combustion chamber						**	✓**  ✓
Apply grease to boom axis-movement points (see Figure K: Lubrication Points on page 18)							
Replace fuel line if necessary							**

\*Service more frequently when used in dusty areas.

\*\*These items should be serviced by a qualified technician.

### Fuel Filter Replacement (if equipped)



**WARNING!** TO PREVENT SERIOUS INJURY FROM FIRE OR EXPLOSION: Fill the fuel tank in a well-ventilated area away from ignition sources. If the engine is hot from use, shut the engine off and wait

for it to cool. Do not smoke.

1. Wear protective gear including, ANSI-approved safety goggles, NIOSH-approved dust mask/respirator, and nitrile gloves.
2. Clean the Fuel Cap and the area around it.
3. Remove Fuel Filter (6R). Reattach Fuel Cap to prevent debris from entering into Gas Tank.
4. Remove Fuel Strainer. Wash with warm water and light detergent. Flush and let dry.
5. Reinstall in the Gas Tank.

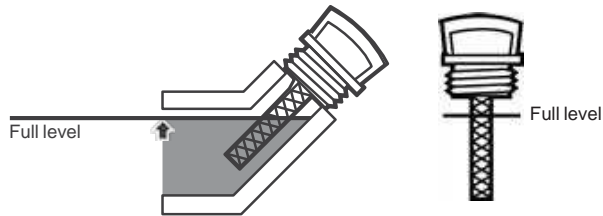

7. Add the appropriate type of oil until the oil level is at the full level. SAE 10W-30 oil is recommended for general use. The SAE Viscosity Grade chart shows other viscosities to use in different average temperatures.

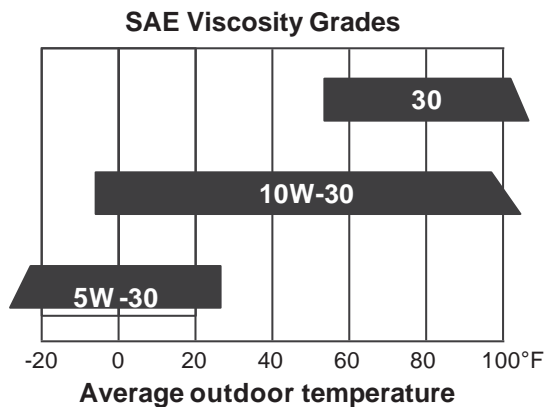

8. Thread the dipstick back in clockwise.

**NOTICE:** Do not run the engine with too little oil. Engine will not start with low or no engine oil.

### Engine Oil Change

**CAUTION!** Oil is very hot during operation and can cause burns. Wait for engine to cool before changing oil.

1. Make sure the engine is stopped and is level.
2. Close the Fuel Valve.
3. Place a drain pan (not included) underneath the crankcase's drain plug.
4. Remove the drain plug and, if possible, tilt the crankcase slightly to help drain the oil out. Recycle used oil.
5. Replace the drain plug and tighten it.
6. Clean the top of the Dipstick and the area around it. Remove the Dipstick by turning it counterclockwise, and wipe it off with a clean, lint free rag.

Grease all grease points  
Every 8 Hours Of Use

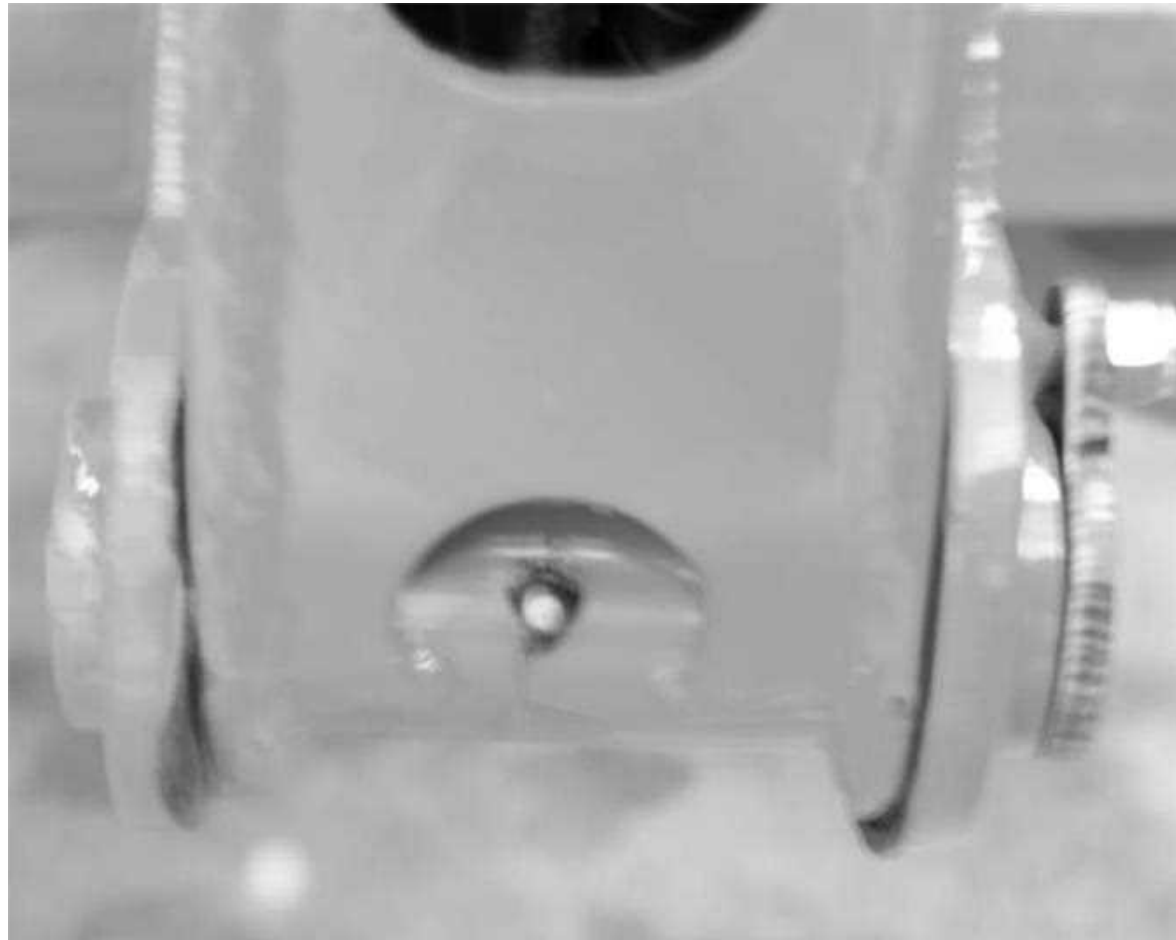

## Air Filter Element Maintenance

1. Remove the air filter cover and the air filter elements and check for dirt. Clean as described below.
2. **Cleaning:**
  - For "paper" filter elements:  
To prevent injury from dust and debris, wear ANSI-approved safety goggles, NIOSH-approved dust mask/respirator, and heavy-duty work gloves. In a well-ventilated area away from bystanders, use pressurized air to blow dust out of the air filter.  
If this does not get the filter clean, replace it.
  - For foam filter elements:  
Wash the element in warm water and mild detergent several times. Rinse. Squeeze out excess water and allow it to dry completely. Soak the filter in lightweight oil briefly, then squeeze out the excess oil.
3. Install the cleaned filter. Secure the Air Cleaner Cover before use.

## Spark Plug Maintenance

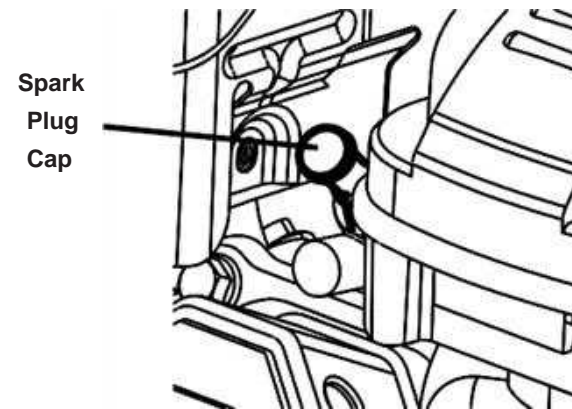

1. Disconnect Spark Plug Cap from end of Plug. Clean out debris from around Spark Plug.
2. Using a spark plug wrench, remove the Spark Plug.
3. Inspect the Spark Plug:  
If the electrode is oily, clean it using a clean, dry rag. If the electrode has deposits on it, polish it using emery paper. If the white insulator is cracked or chipped, the Spark Plug needs to be replaced.

<b>Recommended Spark Plugs</b>
--------------------------------

F7TC (Torch)
--------------

**NOTICE:** Using an incorrect spark plug may damage the engine.

4. When installing a new spark plug, adjust the plug's gap to the specification on the Specifications chart. Do not pry against the electrode; the spark plug can be damaged.
5. Install the new spark plug or the cleaned spark plug into the engine.
  - **Gasket-style:**  
Finger-tighten until the Gasket contacts the Cylinder Head, then tighten about 1/2-2/3 turn more.
  - **Non-gasket-style:**  
Finger-tighten until the plug contacts the Cylinder Head, then tighten about 1/16 turn more.

**NOTICE:** Tighten the Spark Plug properly. **If loose**, the Spark Plug will cause the engine to overheat. **If overtightened**, the threads in the engine block will be damaged.

6. Apply dielectric spark plug boot protector (not included) to the end of the Spark Plug and reattach the wire securely.



---

## Long-Term Storage

When the equipment is to remain idle for longer than 20 days, prepare the engine for storage as follows:

### 1. CLEANING:

Wait for engine to cool, then clean engine with dry cloth. **NOTICE:** Do not clean using water. The water will gradually enter the engine and cause rust damage. Apply a thin coat of rust preventive oil to all metal parts.

### 2. FUEL:

To protect the fuel tank during storage, fill the tank with gasoline that has been treated with a fuel stabilizer additive. Follow fuel stabilizer manufacturer's recommendations for use. Refer to *Checking and Filling Fuel* on page 16.



### **WARNING! TO PREVENT SERIOUS INJURY FROM FIRE:**

Fill tank in a well-ventilated area away from ignition sources. If the engine is hot from use, shut the engine off and wait for it to cool before adding fuel. Do not smoke.

### 3. LUBRICATION:

- a. Change engine oil.
- b. Clean out area around spark plug.  
Remove spark plug and pour one tablespoon of engine oil into cylinder through spark plug hole.
- c. Replace spark plug, but leave spark plug cap disconnected.
- d. Pull Starter Handle to distribute oil in cylinder. Stop after one or two revolutions when you feel the piston start the compression stroke (when you start to feel resistance).

### 4. BATTERY:

Disconnect battery cables (if equipped). Recharge batteries monthly while in storage.

### 5. STORAGE AREA:

Cover and store in a dry, level, well-ventilated area out of reach of children. Storage area should also be away from ignition sources, such as water heaters, clothes dryers, and furnaces.

**NOTICE:** During extended storage periods the Engine must be started every 3 months and allowed to run for 15–20 minutes or the Warranty is VOID.

### 6. STARTING ENGINE DURING/AFTER STORAGE:

Before starting the Engine during or after storage, keep in mind that untreated gasoline will deteriorate quickly. Drain the fuel tank and change to fresh fuel if untreated gasoline has been sitting for a month, if treated gasoline has been sitting beyond the fuel stabilizer's recommended time period, or if the Engine does not start. For Engine starting instructions refer to Starting the Engine on page 10.

Follow all safety precautions whenever diagnosing or servicing the equipment or engine.

## Troubleshooting

Problem	Possible Causes	Probable Solutions
 <p>Engine will not start</p>	<p><b>FUEL RELATED:</b></p> <ol style="list-style-type: none"> <li>No fuel in tank or fuel valve closed.</li> <li>Choke not in START position, cold engine.</li> <li>Gasoline with more than 10% ethanol used. (E15, E20, E85, etc.)</li> <li>Low quality or deteriorated, old gasoline.</li> <li>Carburetor not primed.</li> <li>Dirty fuel passageways.</li> <li>Carburetor needle stuck. Fuel can be smelled in the air.</li> <li>Too much fuel in chamber. This can be caused by the carburetor needle sticking.</li> <li>Clogged Fuel Filter.</li> </ol>	<p><b>FUEL RELATED:</b></p> <ol style="list-style-type: none"> <li>Fill fuel tank with fresh 87+ octane stabilizer-treated unleaded gasoline and open fuel valve. <b>Do not use gasoline with more than 10% ethanol (E15, E20, E85, etc.).</b></li> <li>Move Choke to START position.</li> <li>Clean out ethanol rich gasoline from fuel system. Replace components damaged by ethanol. Use fresh 87+ octane stabilizer-treated unleaded gasoline only. <b>Do not use gasoline with more than 10% ethanol (E15, E20, E85, etc.).</b></li> <li>Use fresh 87+ octane stabilizer-treated unleaded gasoline. <b>Do not use gasoline with more than 10% ethanol (E15, E20, E85, etc.).</b></li> <li>Pull on Starter Handle to prime.</li> <li>Clean out passageways using fuel additive. Heavy deposits may require further cleaning.</li> <li><b>Gently</b> tap side of carburetor float chamber with screwdriver handle.</li> <li>Turn Choke to RUN position. Remove spark plug and pull the start handle several times to air out the chamber. Reinstall spark plug and set Choke to START position.</li> <li>Replace Fuel Filter.</li> </ol>
	<p><b>IGNITION (SPARK) RELATED:</b></p> <ol style="list-style-type: none"> <li>Spark plug cap not connected securely.</li> <li>Spark plug electrode wet or dirty.</li> <li>Incorrect spark plug gap.</li> <li>Spark plug cap broken.</li> <li>Incorrect spark timing or faulty ignition system.</li> </ol>	<p><b>IGNITION (SPARK) RELATED:</b></p> <ol style="list-style-type: none"> <li>Connect spark plug cap properly.</li> <li>Clean spark plug.</li> <li>Correct spark plug gap.</li> <li>Replace spark plug cap.</li> <li>Have qualified technician diagnose/repair ignition system.</li> </ol>
	<p><b>COMPRESSION RELATED:</b></p> <ol style="list-style-type: none"> <li>Cylinder not lubricated. Problem after long storage periods.</li> <li>Loose or broken spark plug. (Hissing noise will occur when trying to start.)</li> <li>Loose cylinder head or damaged head gasket. (Hissing noise will occur when trying to start.)</li> <li>Engine valves or tappets mis-adjusted or stuck.</li> </ol>	<p><b>COMPRESSION RELATED:</b></p> <ol style="list-style-type: none"> <li>Pour tablespoon of oil into spark plug hole. Crank engine a few times and try to start again.</li> <li>Tighten spark plug. If that does not work, replace spark plug. If problem persists, may have head gasket problem, see #3.</li> <li>Tighten head. If that does not remedy problem, replace head gasket.</li> <li>Have qualified technician adjust/repair valves and tappets.</li> </ol>
	<p><b>ENGINE OIL RELATED:</b></p> <ol style="list-style-type: none"> <li>Low engine oil.</li> <li>Engine mounted on slope, triggering low oil shutdown.</li> </ol>	<p><b>ENGINE OIL RELATED:</b></p> <ol style="list-style-type: none"> <li>Fill engine oil to proper level. Check engine oil before EVERY use.</li> <li>Operate engine on level surface. Check engine oil level.</li> </ol>

Problem	Possible Causes	Probable Solutions
Engine misfires	<ol style="list-style-type: none"> <li>1. Spark plug cap loose.</li> <li>2. Incorrect spark plug gap or damaged spark plug.</li> <li>3. Defective spark plug cap.</li> <li>4. Old or low quality gasoline.</li> <li>5. Incorrect compression.</li> </ol>	<ol style="list-style-type: none"> <li>1. Check cap and wire connections.</li> <li>2. Re-gap or replace spark plug.</li> <li>3. Replace spark plug cap.</li> <li>4. Use only fresh 87+ octane stabilizer-treated unleaded gasoline. <b>Do not use gasoline with more than 10% ethanol (E15, E20, E85, etc.).</b></li> <li>5. Diagnose and repair compression. (Use <b>Engine will not start: COMPRESSION RELATED</b> section.)</li> </ol>
Engine stops suddenly	<ol style="list-style-type: none"> <li>1. Fuel tank empty or full of impure or low quality gasoline.</li> <li>2. Low oil shutdown.</li> <li>3. Defective fuel tank cap creating vacuum, preventing proper fuel flow.</li> <li>4. Faulty magneto.</li> <li>5. Disconnected or improperly connected spark plug cap.</li> </ol>	<ol style="list-style-type: none"> <li>1. Fill fuel tank with fresh 87+ octane stabilizer-treated unleaded gasoline. <b>Do not use gasoline with more than 10% ethanol (E15, E20, E85, etc.).</b></li> <li>2. Fill engine oil to proper level. Check engine oil before EVERY use.</li> <li>3. Test/replace fuel tank cap.</li> <li>4. Have qualified technician service magneto.</li> <li>5. Secure spark plug cap.</li> </ol>
Engine stops when under heavy load	<ol style="list-style-type: none"> <li>1. Dirty air filter</li> <li>2. Engine running cold.</li> </ol>	<ol style="list-style-type: none"> <li>1. Clean element.</li> <li>2. Allow engine to warm up prior to operating equipment.</li> </ol>
Engine knocks	<ol style="list-style-type: none"> <li>1. Old or low quality gasoline.</li> <li>2. Engine overloaded.</li> <li>3. Incorrect spark timing, deposit buildup, worn engine, or other mechanical problems.</li> </ol>	<ol style="list-style-type: none"> <li>1. Fill fuel tank with fresh 87+ octane stabilizer-treated unleaded gasoline. <b>Do not use gasoline with more than 10% ethanol (E15, E20, E85, etc.).</b></li> <li>2. Do not exceed equipment's load rating.</li> <li>3. Have qualified technician diagnose and service engine.</li> </ol>
 <p>After sudden impact, engine will run, but equipment will not operate</p>	<ol style="list-style-type: none"> <li>1. Impure or low quality gasoline.</li> <li>2. Engine too cold.</li> <li>3. Intake valve stuck or overheated engine.</li> <li>4. Incorrect timing. Shaft key or other shear pin broken by impact to disconnect engine and limit damage.</li> </ol>	<ol style="list-style-type: none"> <li>1. Fill fuel tank with fresh 87+ octane stabilizer-treated unleaded gasoline. <b>Do not use gasoline with more than 10% ethanol (E15, E20, E85, etc.).</b></li> <li>2. Use cold weather fuel and oil additives to prevent backfiring.</li> <li>3. Have qualified technician diagnose and service engine.</li> <li>4. Check engine timing. Have qualified technician check and replace broken shaft key or other shear pins.</li> </ol>
Trencher loses performance	<ol style="list-style-type: none"> <li>1. Mushy hydraulic operation.</li> <li>2. Oil Leaks.</li> </ol>	<ol style="list-style-type: none"> <li>1. Bleed hydraulic system. Replace hydraulic filter/clean strainer.</li> <li>2. Tighten/replace hose.</li> </ol>

## **Warranty**

Unless otherwise stated in the materials that arrive with your product, U-Dig Backhoes are warranted for one (1) year against defects in materials or workmanship when put to ordinary and normal consumer use; ninety (90) days for any other use.

For the purposes of all the above warranties, "ordinary and normal consumer use" refers to non-commercial residential use and does not include misuse, accidents or damage due to inadequate maintenance.

U-Dig certifies that your U-Dig Backhoe is fit for ordinary purposes for which products of its type are used. U-Dig however, limits the implied warranties of merchantability and fitness in duration to a period of 1 year in consumer use, ninety (90) days for any other use.

The 1 Year Limited Warranty on a U-Dig Towable Backhoe starts on the date the machine ships from our building. The 1-Year Limited Warranty is applicable only to the original owner.

The warranty holder is responsible for the performance of the required maintenance as defined by the manufacturer's owner's manuals. The warranty holder is responsible for replacement of normally wearing parts such as air filters, hydraulic oil filters, highway tires, hydraulic hoses, spark plugs and teeth. Accessories to the machine are not covered by this warranty. During the warranty period, the warranty holder is responsible for the machine transportation charges, if required. During the warranty period, warranty parts will be shipped by standard method at no charge to the warranty holder. Expedited shipping of warranty parts is the responsibility of the warranty holder.